



# INSTALLATION INSTRUCTIONS

<b>Accessory</b> <b>SADDLEBAG SET (29 Liter)</b> <b>P/N 08L76-MGS-A50</b>	<b>Application</b> <b>NC700X/XD</b>	<b>Publication No.</b> <b>MII 13973</b>
		<b>Issue Date</b> <b>October 2012</b>

**Honda Dealer: Please give a copy of these instructions to your customer.**

## PARTS LIST

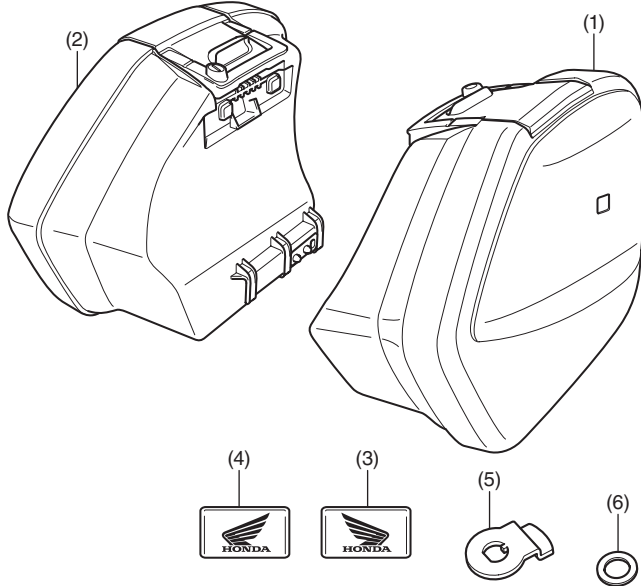

No.	Description	Qty
(1)	Right saddlebag	1
(2)	Left saddlebag	1
(3)	Right emblem	1
(4)	Left emblem	1
(5)	Plate	2
(6)	Washer (use at Step 18)	2

### 1 KEY BODY PARTS

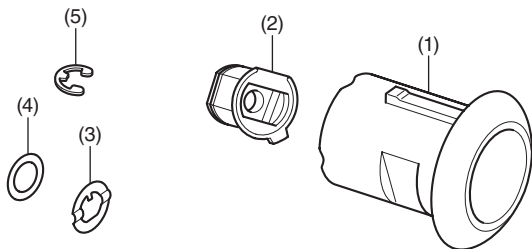

There are two of this kit in the saddlebag case.

No.	Description	Qty
(1)	Cylinder body	1
(2)	Inner joint	1
(3)	Spring plate	1
(4)	Washer (do not use)	1
(5)	E-ring	1

### 1 KEY INNER CYLINDER

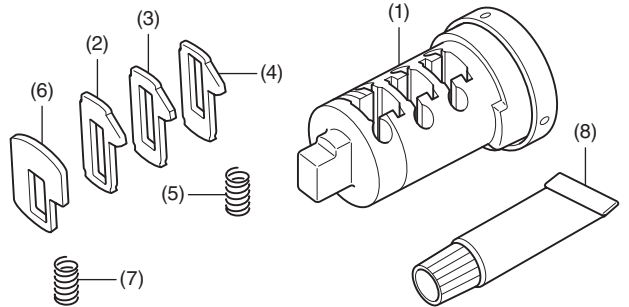

There are two of this kit in the saddlebag case.

No.	Description	Qty
(1)	Inner cylinder	1
(2)	Tumbler A (Gold)	5
(3)	Tumbler B (Silver)	5
(4)	Tumbler C (Gold)	5
(5)	Spring (Silver)	10
(6)	Stopper tumbler	3
(7)	Stopper spring (Black)	3
(8)	Grease	1

### SADDLEBAG SUPPORT BRACKET and REAR CARRIER/SADDLEBAG BRACKET Sold separately

The items below are required for saddlebag installation.

- Saddlebag Support Bracket
- Rear Carrier/Saddlebag Bracket

## USE AND CARE INFORMATION

- The weight of the cargo must not exceed the following maximum weight capacity:

Maximum Weight Capacity	
Right saddlebag	13.2 lb (6.0 kg)
Left saddlebag	13.2 lb (6.0 kg)

- Check the accessory mounts frequently.
- Load weight equally on both sides to minimize imbalance. If the weight is not loaded equally on both sides or if it exceeds the maximum weight capacity of this accessory, handling will be compromised, which could result in a crash and serious injury.
- Do not store valuables or easily breakable items in the saddlebags.
- Don't place a heavy object on the opened lid or apply an excessive force from the top of opened lid.
- Be sure that the saddlebags are installed securely before riding.
- Always install saddlebags on both the left and the right side.
- The saddlebags are not perfectly watertight, and water may enter when washing the motorcycle, or when it rains.
- The saddlebag can get hot while the engine is running and after it has been stopped (after riding etc.).

The lower part of the right saddlebag, close to the muffler, can become especially hot, allow the saddlebag to cool for some time before touching this area.

## < Notes regarding the key cylinder >

- This product is used to assemble a key cylinder matching the motorcycle key by combining three types of tumblers.
- When this key cylinder is installed in a box or similar equipment, the installed equipment can be operated with the motorcycle key.

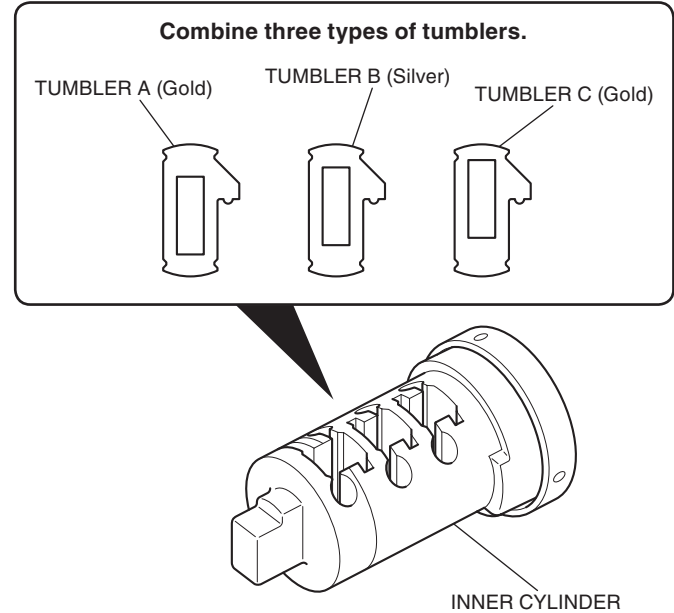

## INSTALLATION

- As two key cylinders are required, make two cylinders using following procedures.

### CAUTION:

- To prevent burns, allow the engine, exhaust system, radiator, etc., to cool before installing the accessory.

- The three tumbler types shown are provided.

- The  part has a different width for each of the three tumbler types.
- As the tumblers are small, keep them in the bag until they are used.

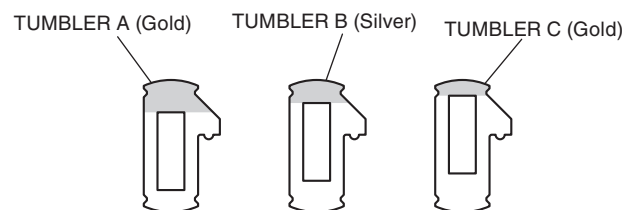

The stopper tumbler will be used later.

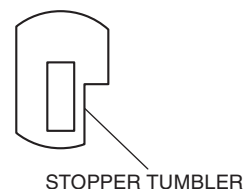

- Install the tumblers and springs (silver) as shown.
  - Install five tumblers of the same type.

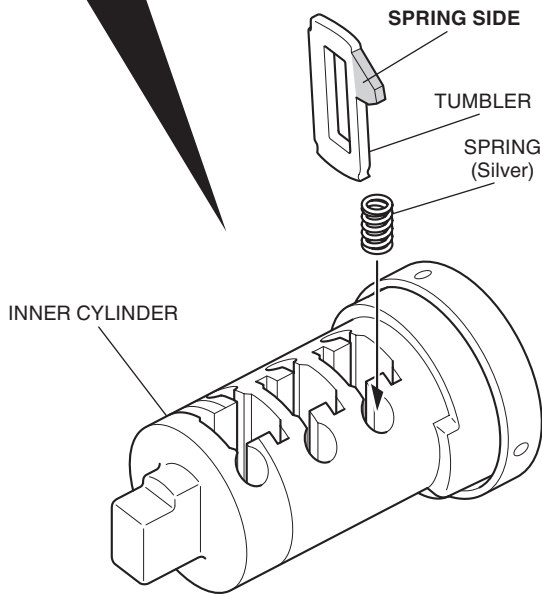
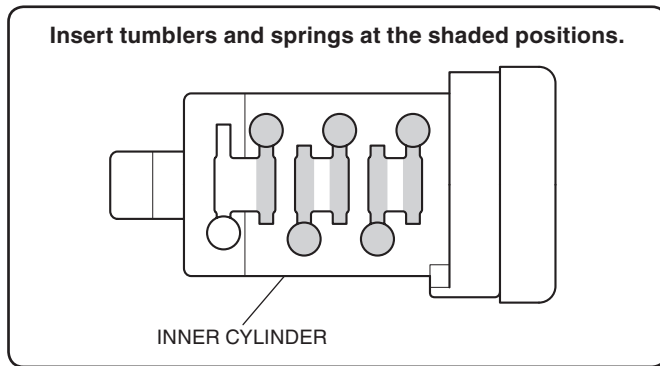

- Insert the key as shown.
  - Lightly push down on the tumblers from above, then insert the key.

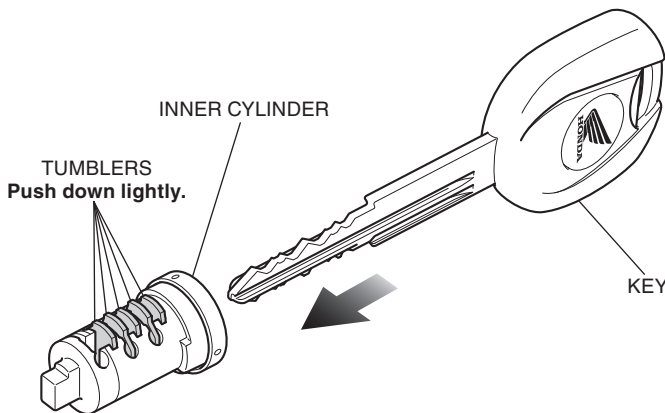

- Confirm that some tumblers are projecting. Mark the positions of the projected tumblers.
  - The positions where tumblers project and the projecting height differ according to the key.

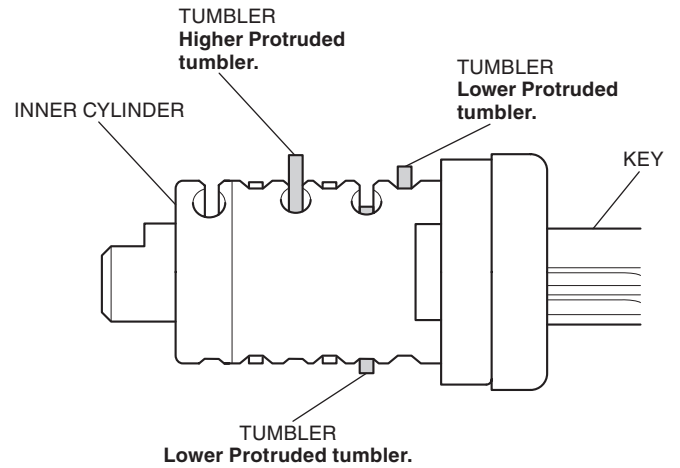

- Press down lightly on the tumbler, pull the key out.
  - The tumbler spring may jump out when the tumbler is not pressed down lightly.

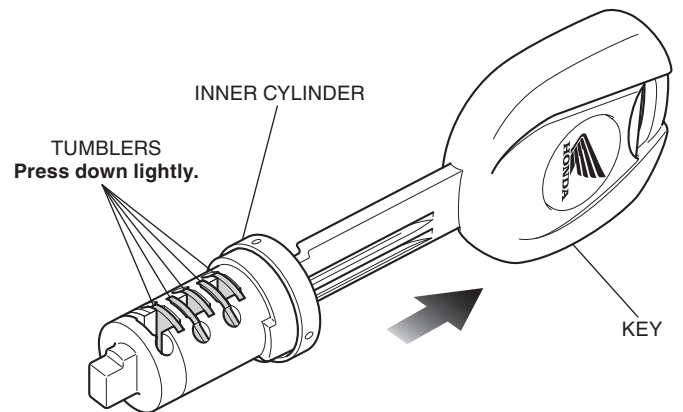

- Pull out the projecting tumbler(s).
  - Leave the spring(s) installed.

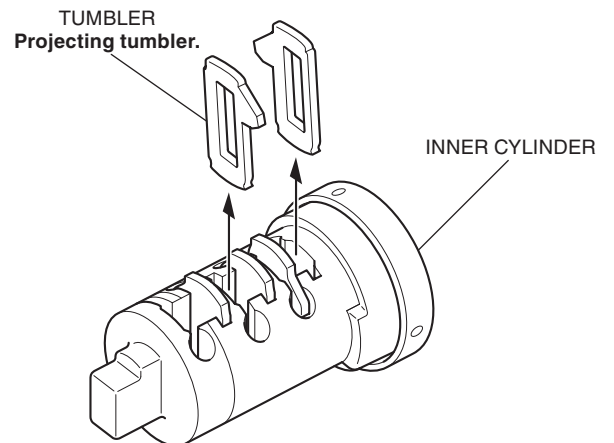

7. Insert a different tumbler(s) at the marked positions.

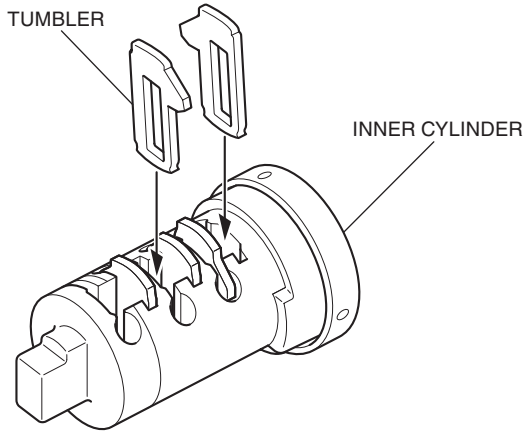

8. Repeat steps 3 to 7, inserting different tumblers at the marked positions until no tumblers are projected.

- **Lightly push down on the tumblers from above, then insert the key.**

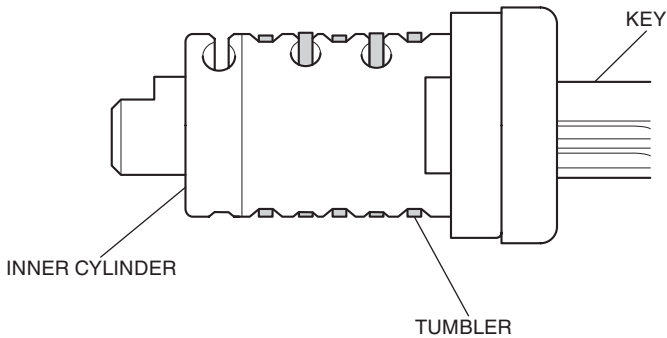

9. Insert the assembled inner cylinder into the cylinder body as shown.

- **Confirm the inner cylinder turns clockwise smoothly.**

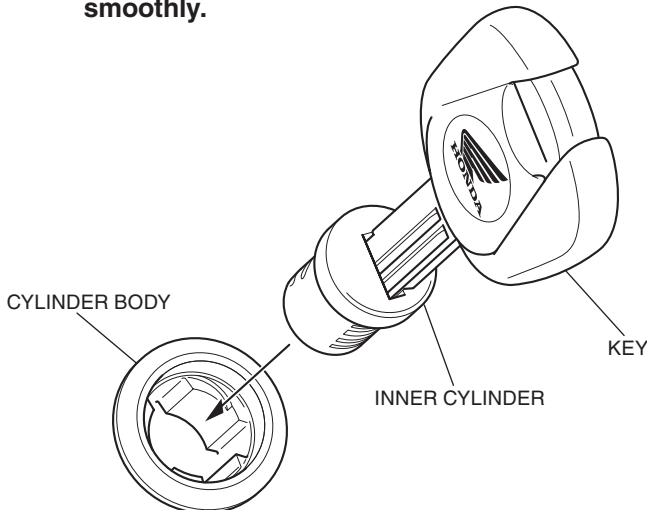

10. Pull out the inner cylinder.

11. Push down lightly on the tumblers and pull out the key.

12. Install the stopper tumbler and the stopper spring (black) as shown.

**Insert the stopper tumbler and a stopper spring at the shaded position.**

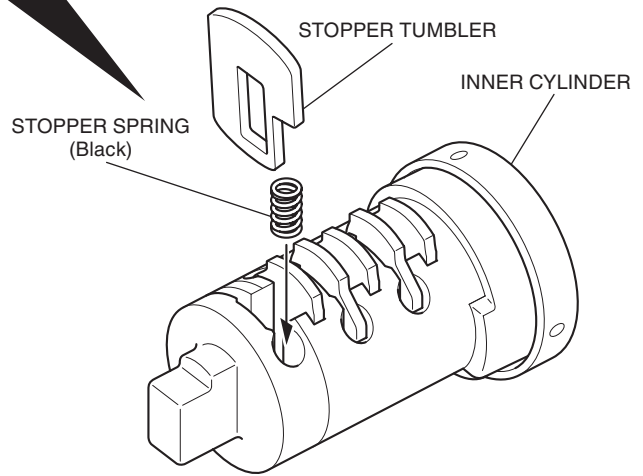
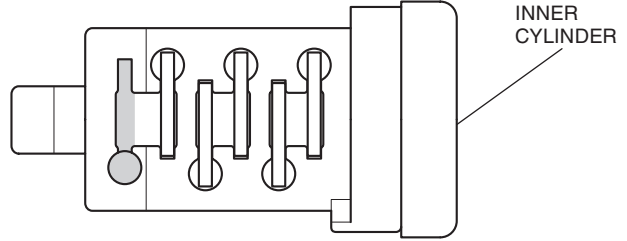

13. Insert the key as shown.

- **Lightly push down on the tumblers from above, then insert the key.**
- **Confirm that the stopper tumbler jumps out.**

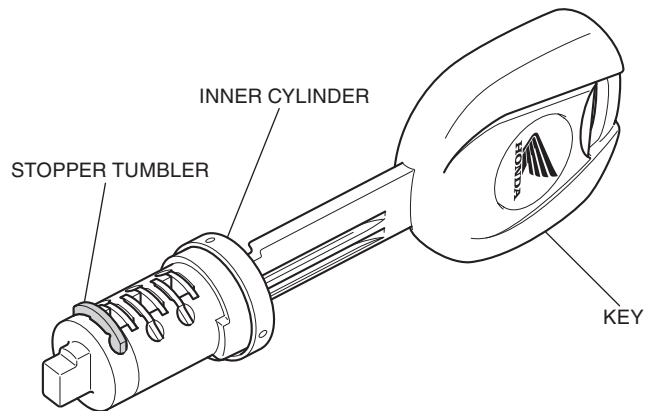

14. Apply grease to the shaded areas as shown.
- Apply to the tumbler and to the outer circumference of the inner cylinder.
  - Only use the supplied grease.

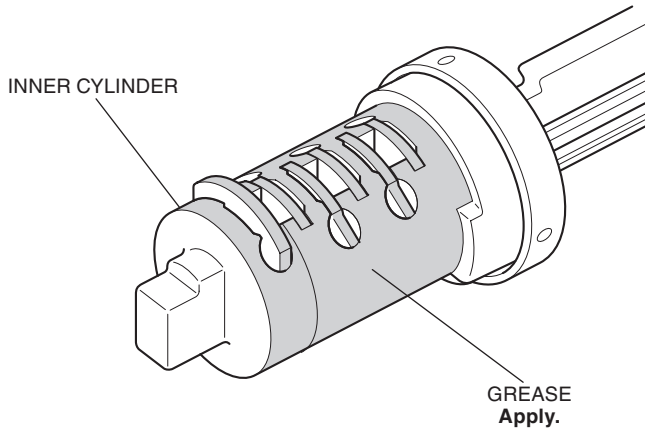

- 15 Install the inner joint into the cylinder body as shown.

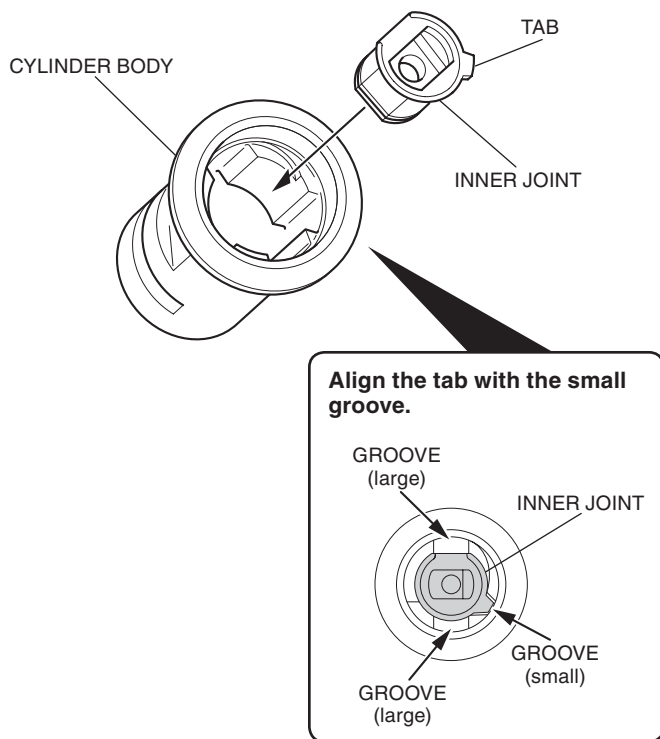

16. Install the inner cylinder by sliding the stopper tumbler along the slide guide while rotating it.
- If the inner cylinder cannot be inserted, again confirm that no tumblers other than the stopper tumbler have jumped out.

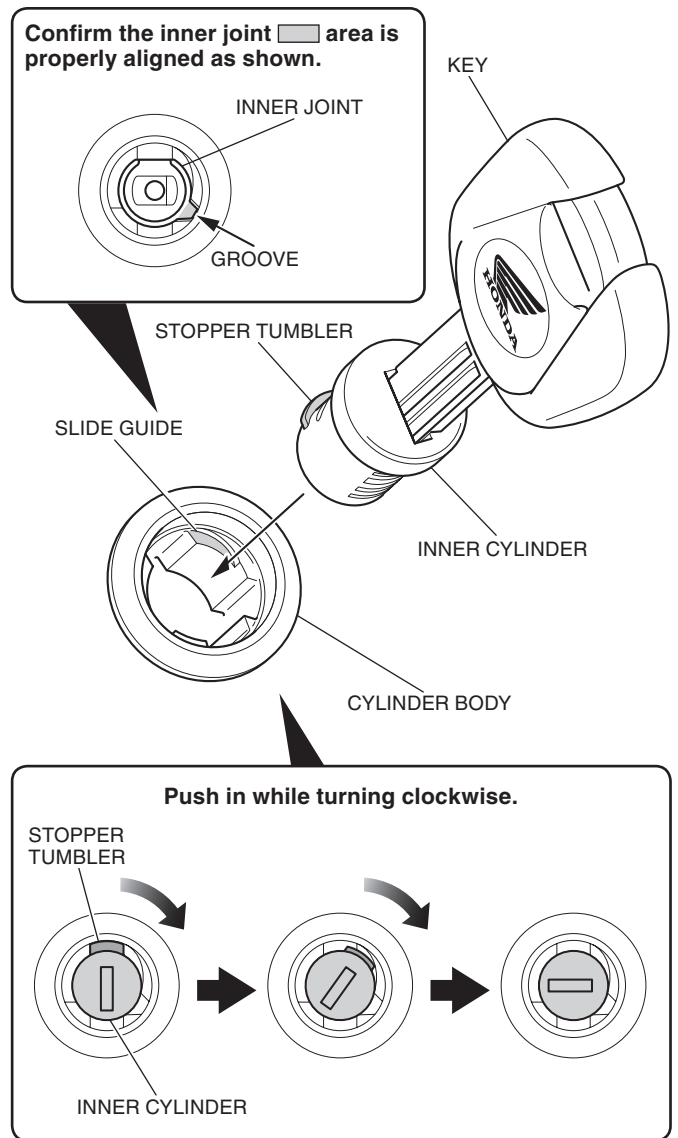

17. Draw out the key and check that the inner cylinder does not come out.

18. Install a cylinder body on each saddlebag as shown.

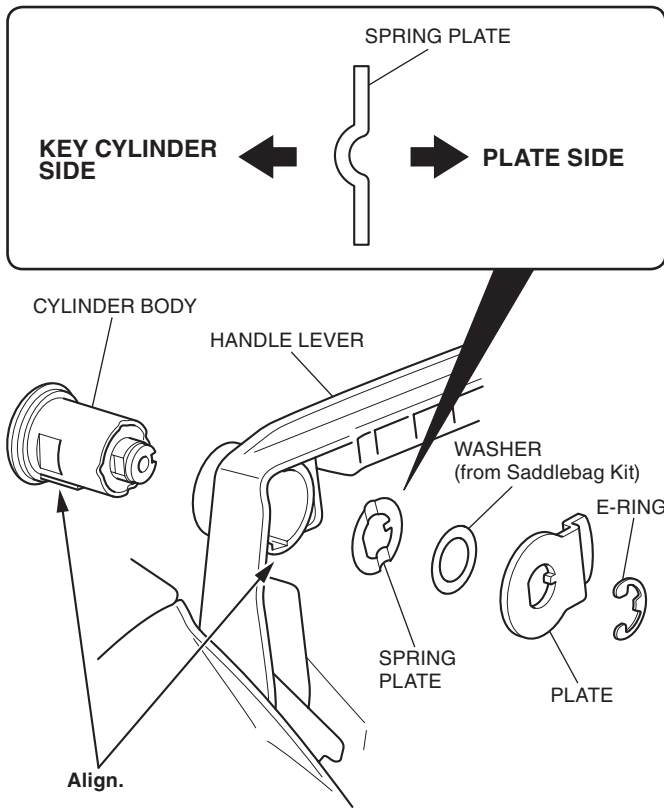

### How to Install the Emblem

1. Attach the right emblem in the position shown.

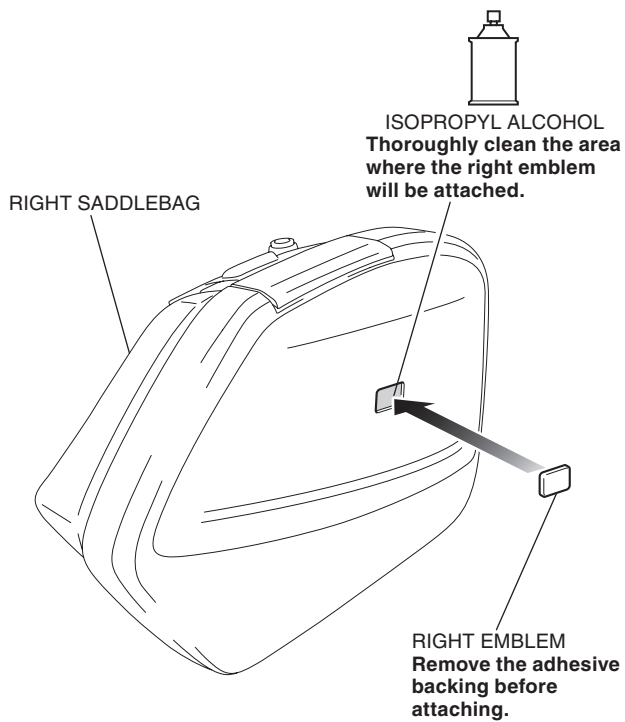

2. Repeat on the left side.

### How to Open and Close the Saddlebags

1. Release the lock by turning the key clockwise.

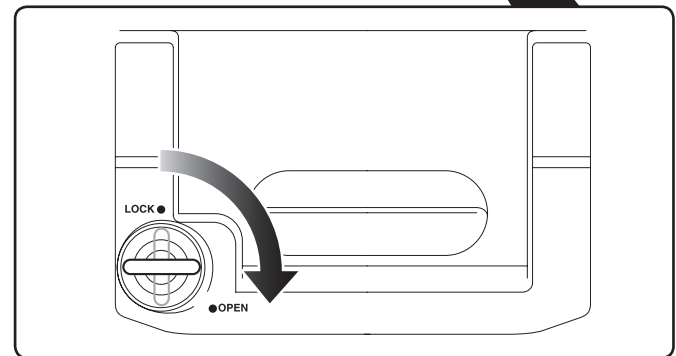
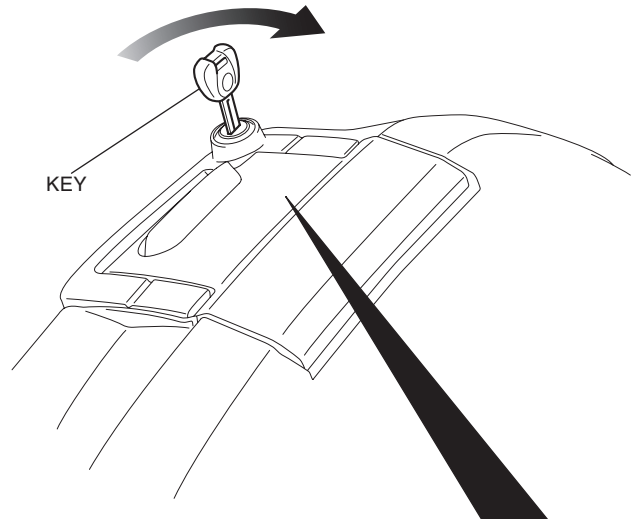

2. With the key turned clockwise, raise the plate lock and release it from the lid.

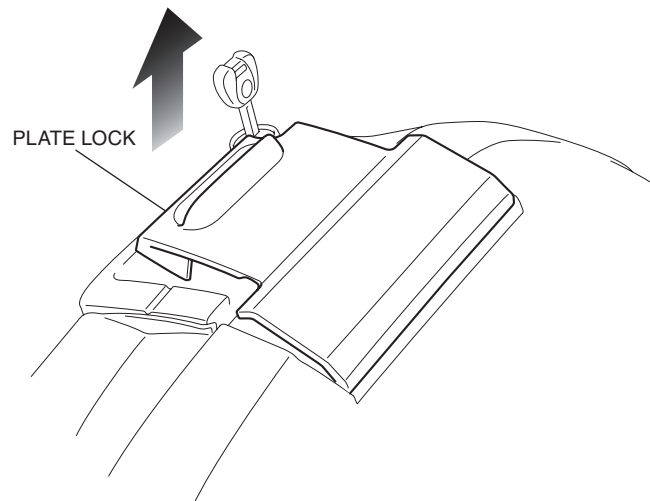

3. Open and close the lid with the plate lock released and raised.

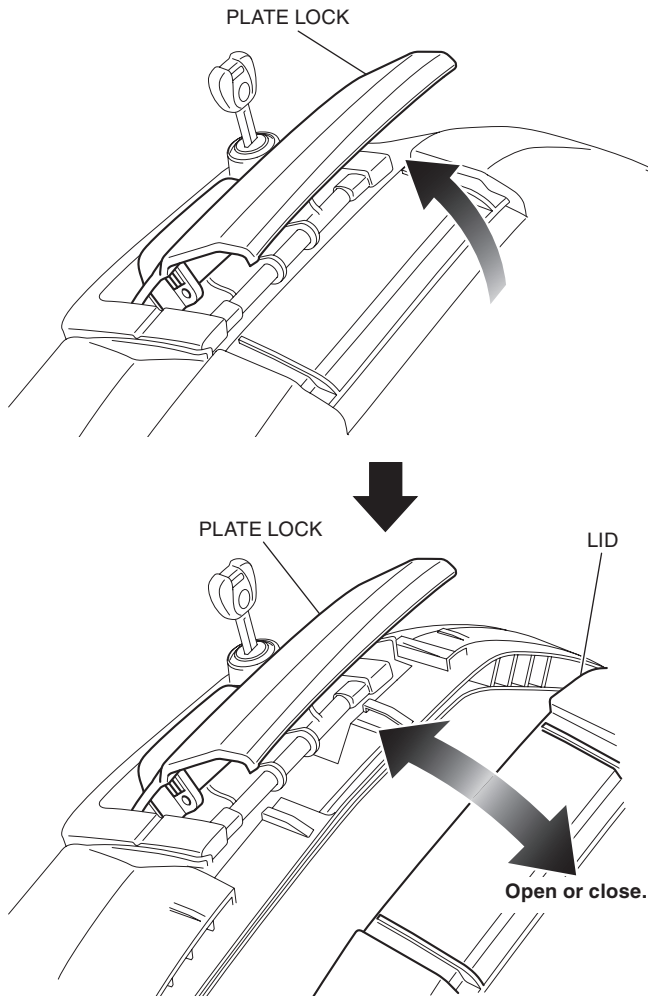

## How to Install the Saddlebags

1. Release the lock by turning the key clockwise.
2. Attach the saddlebag bracket of the right saddlebag to the right saddlebag support stay as shown.

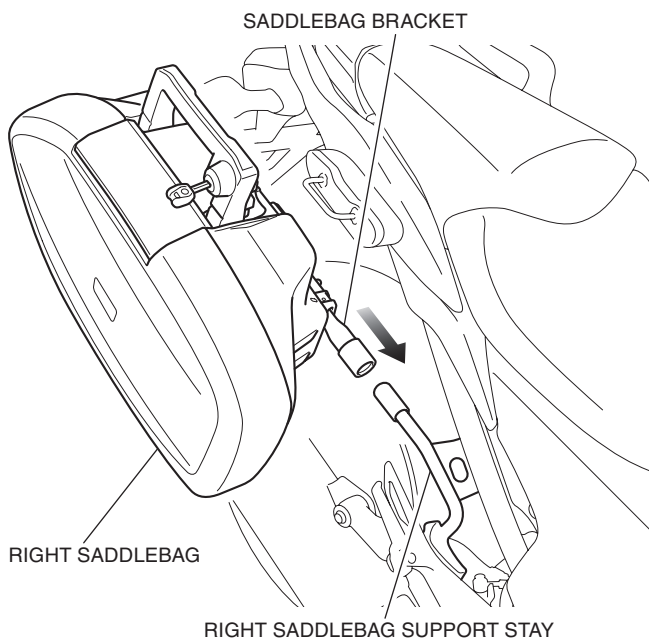

3. Insert the loop of the right saddlebag hook into the upper hole of the right saddlebag as shown.

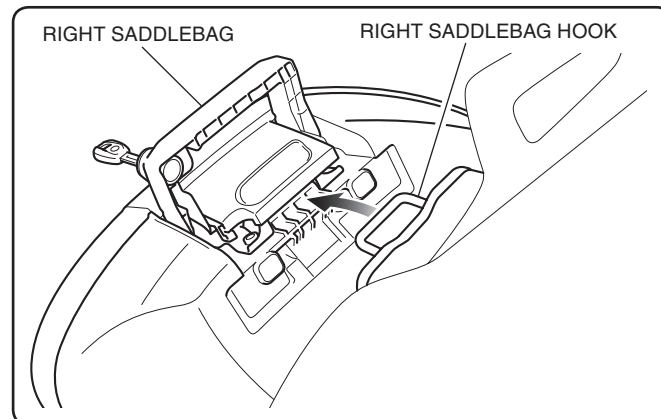

**HANDLE LEVER**  
Install the saddlebag with the handle lever raised.

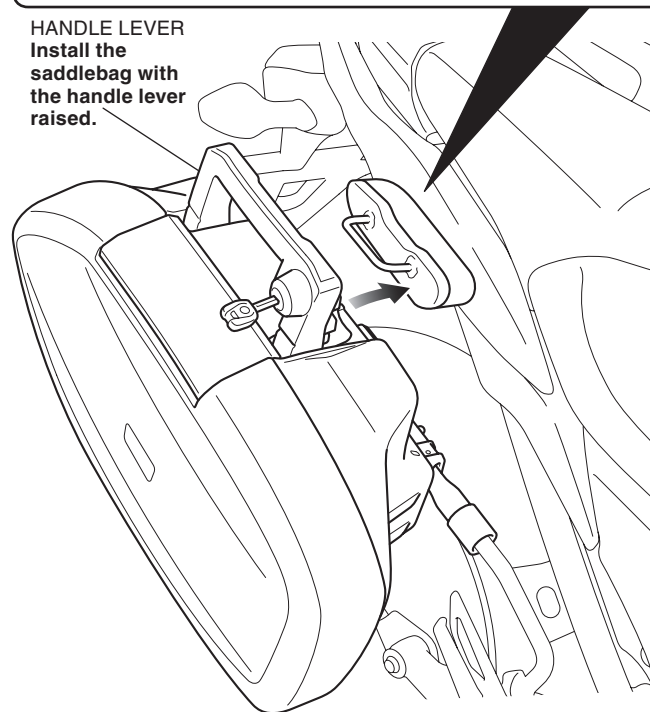



4. Lower the handle lever and lock the right saddlebag by turning the key counterclockwise as shown.

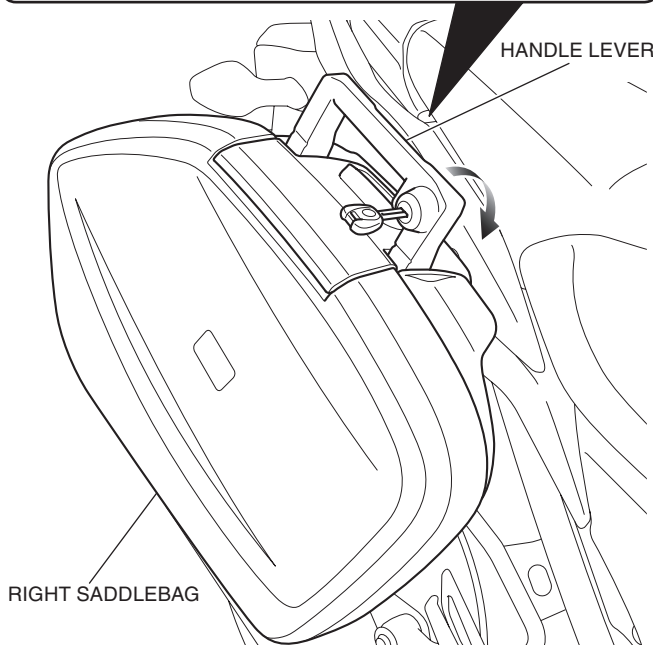
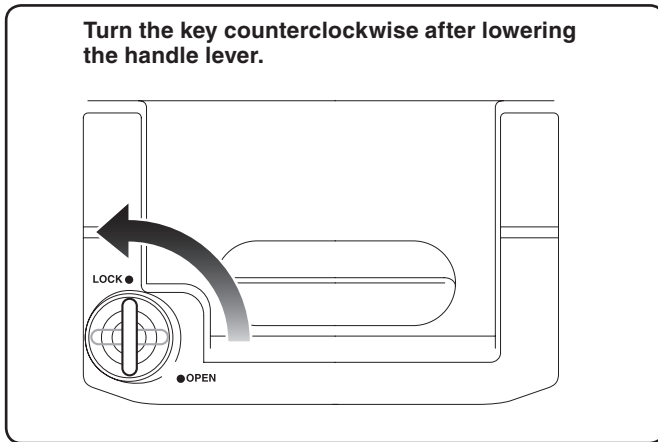

5. Be sure that the handle lever cannot be released and the saddlebag is installed securely.
  - **The saddlebag can come off during riding unless it is mounted securely.**

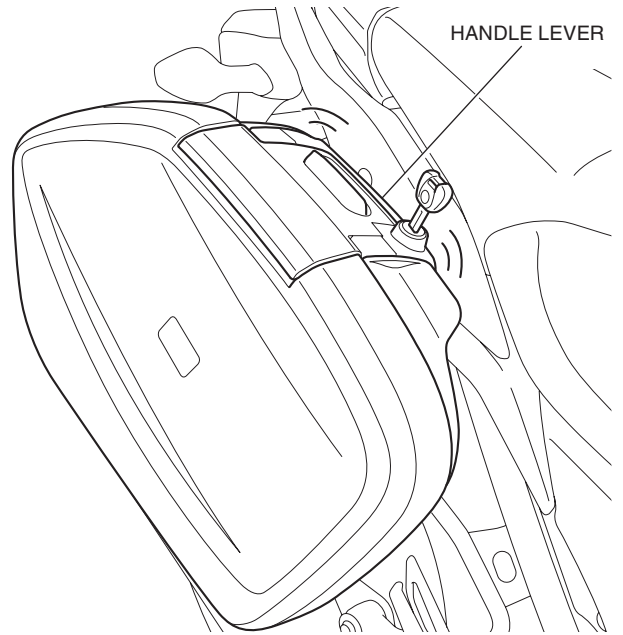

6. Repeat on the left side.

### How to Remove the Saddlebags

1. Remove the saddlebags in the reverse order of installation.