



# INSTALLATION INSTRUCTIONS

Accessory  
**CENTERSTAND**  
**P/N 08M70-MGS-A30**

Application  
**NC700X/XD**

Publication No.  
**MII 13973**  
 Issue Date  
**October 2012**

**Honda Dealer: Please give a copy of these instructions to your customer.**

## PARTS LIST

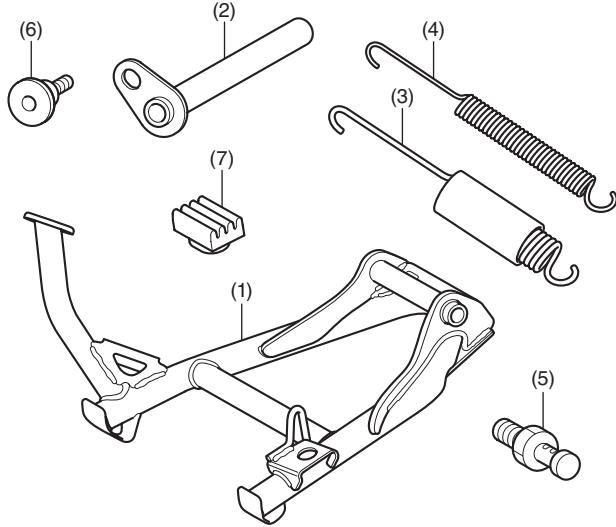

No.	Description	Qty
(1)	Centerstand	1
(2)	Centerstand shaft	1
(3)	Spring (large)	1
(4)	Spring (small)	1
(5)	Spring hook	1
(6)	6 mm socket bolt	1
(7)	Rubber stop	1

## TOOLS AND SUPPLIES REQUIRED

Open-end wrench (12 mm)  
 Hex wrench (5 mm)  
 Spring tool  
 Grease  
 Dish soap solution  
 (Water : dish soap / 100 : 1)  
 Shop towel  
 Torque wrench

## TORQUE CHART

Tighten all screws, bolts, and nuts to their specified torque values. Refer to the Service Manual for the torque values of the removed parts.

Item	N-m	kgf-m	lbf-ft
6 mm socket bolt	12	1.2	9
Spring hook	22	2.2	16

## USE AND CARE INFORMATION

- Check the accessory mounts frequently and retighten if necessary.
- Before starting your motorcycle, check that the sidestand and the centerstand are fully retracted.
- Always set the parking brake when parking the NC700XD (DCT model) on the centerstand.
- Always choose a firm, level surface when setting the centerstand.

## INSTALLATION

### CAUTION:

- To prevent burns, allow the engine, exhaust system, radiator, etc. to cool before installing the accessory.

### NOTE:

- Be extremely careful when installing the springs as the combined tension of the springs is very strong.
- Keep the motorcycle on its sidestand when installing the centerstand.
- The spring installation shall be performed by two people. While one person holds the motorcycle, another person installs the spring.

1. Remove the muffler bolts, washers, and nut as shown.

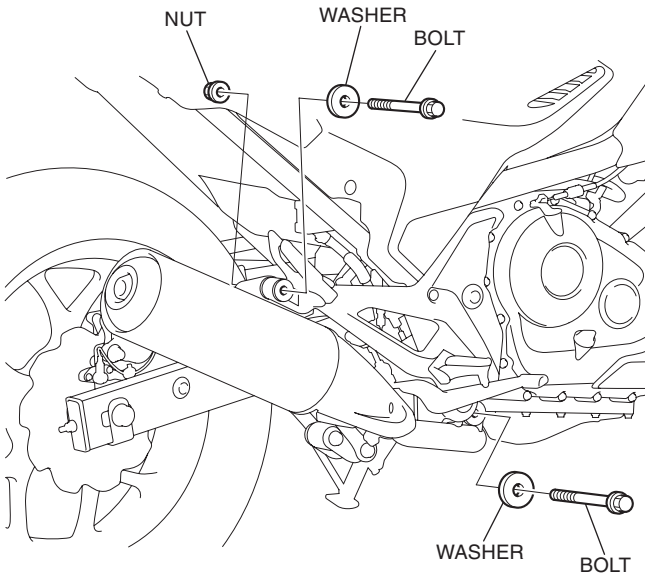

2. Install the spring hook as shown.

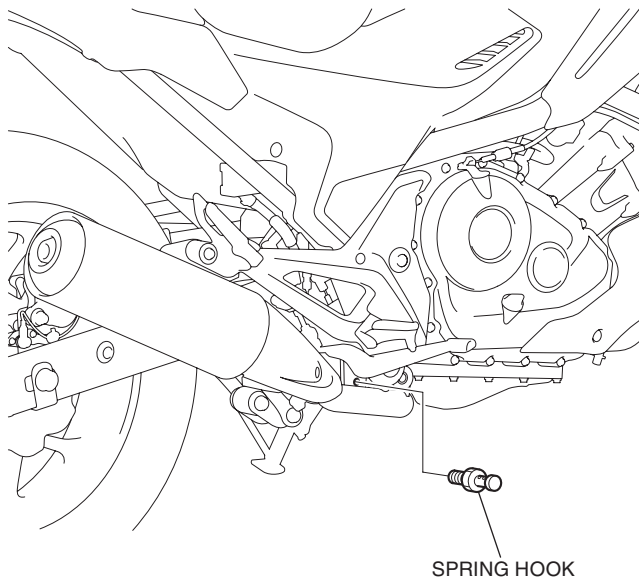

3. Apply dish soap solution to the rubber stop in the area shown.

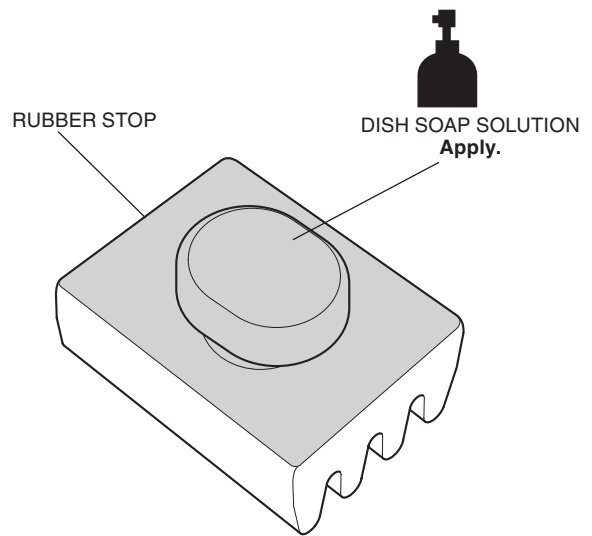

4. Install the rubber stop in the position shown.

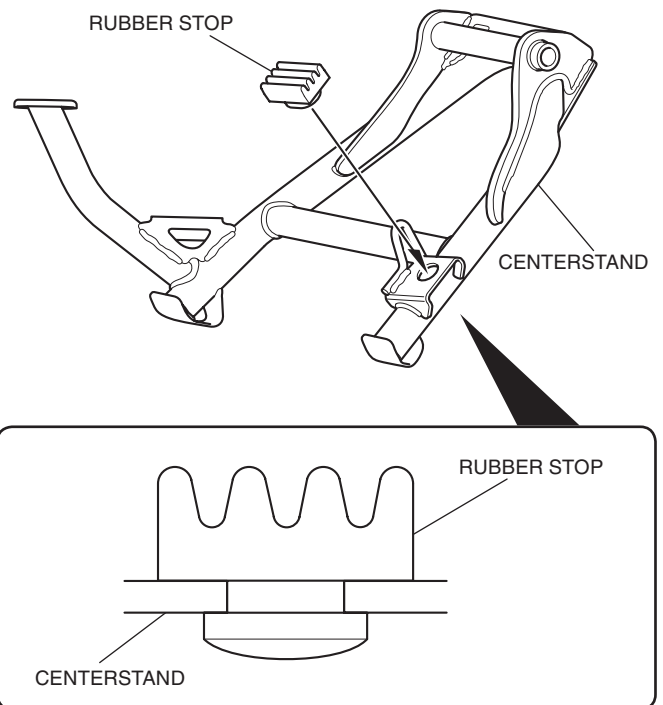

5. Apply grease to the position shown.

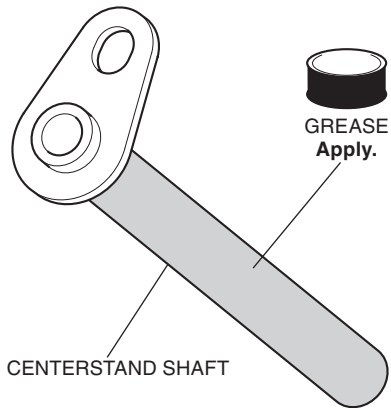

6. Install the centerstand as shown.

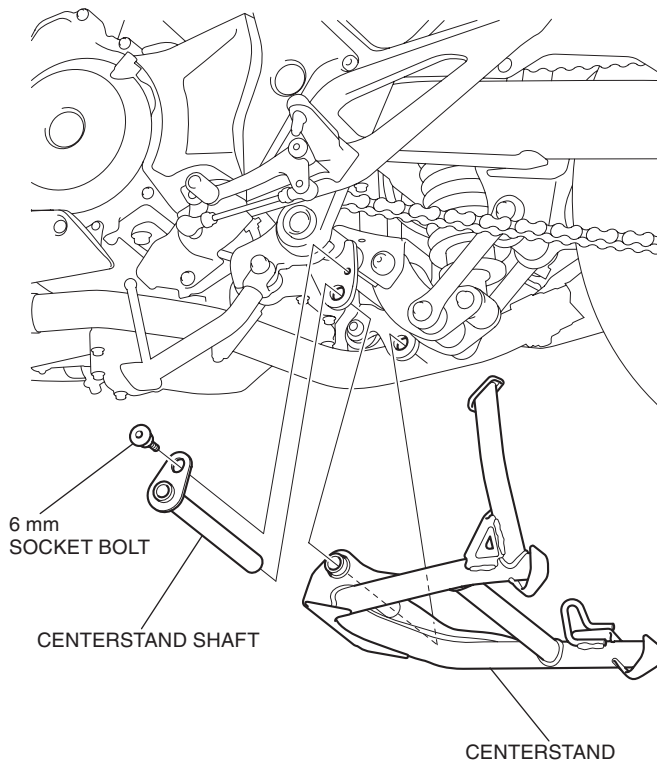

7. Slide the small spring into the large spring as shown.

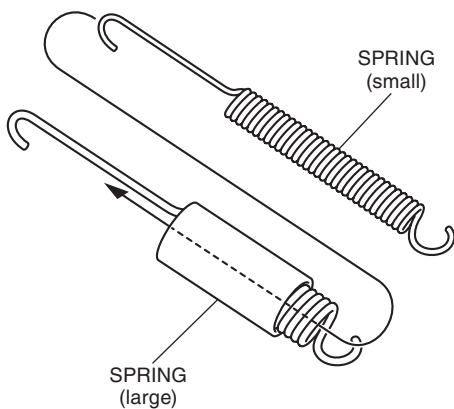

8. Install the spring assembly as shown.

- First install the spring assembly to the spring hook, then to the centerstand.
- The spring installation should be performed by two people. While one person holds the motorcycle, another person installs the spring.
- To ease installation, first hook the small spring.

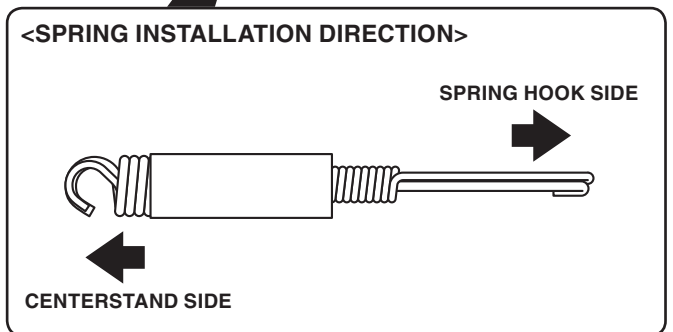
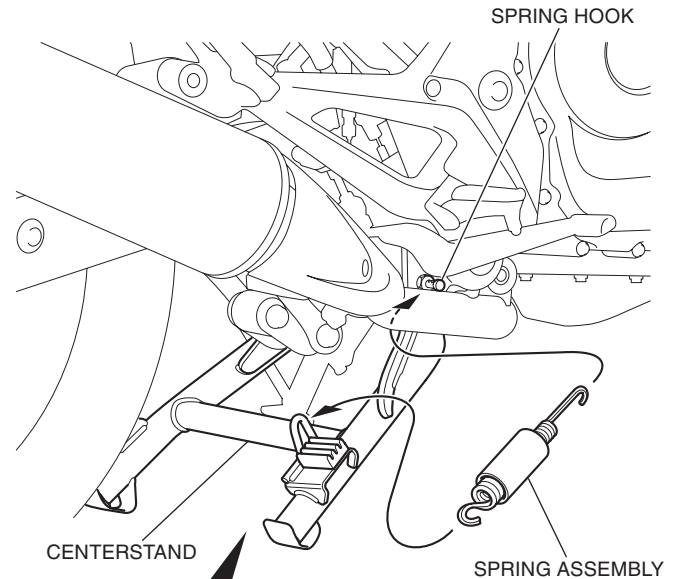

- If the spring assembly is too hard to install, remove the centerstand shaft. First hook the spring assembly, then install the centerstand shaft.

6 mm SOCKET BOLT

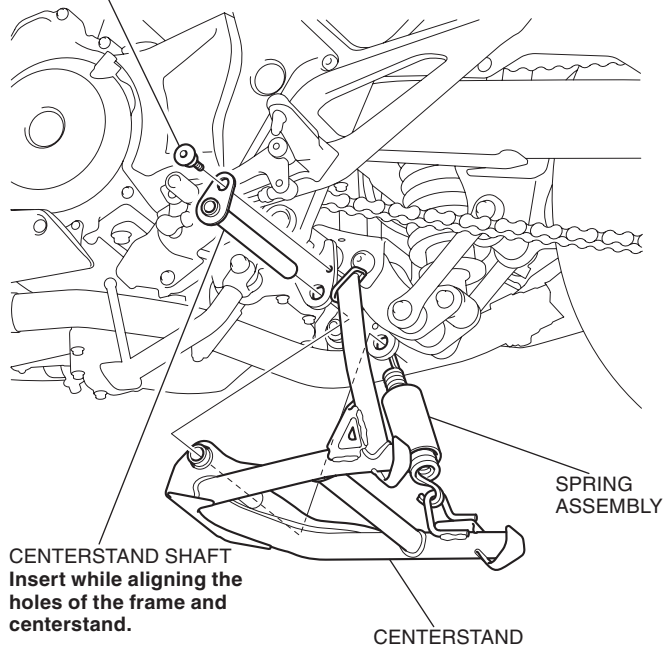

9. Install the muffler bolt, washer, and nut in the reverse order of removal.