



# INSTALLATION INSTRUCTIONS

Accessory  
**LOWER COWL DEFLECTOR**  
 P/N 08R71-MGS-A50

Application  
**NC700XD**

Publication No.  
**MII 13973**  
 Issue Date  
**February 2012**

**Honda Dealer: Please give a copy of these instructions to your customer.**

## PARTS LIST

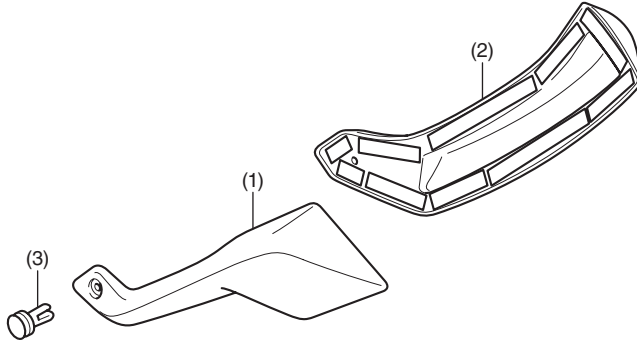

No.	Description	Qty
(1)	Right lower cowl deflector	1
(2)	Left lower cowl deflector	1
(3)	Clip	2

## TOOLS AND SUPPLIES REQUIRED

Electric drill  
 Drill bit (4.0 mm)  
 Awl  
 Scissors  
 Isopropyl alcohol  
 Shop towel

## TORQUE INFORMATION

Refer to the Service Manual for the torque values of the removed parts.

## USE AND CARE INFORMATION

- Check the accessory mounts frequently.
- When this accessory becomes dirty, rinse it thoroughly with cool water to remove loose dirt, then wipe with a clean cloth or sponge. Do not use a brush to clean this accessory as it may scratch the surface.
- Never use petroleum solvents such as gasoline, thinner or benzene to clean this accessory. Also do not use acid or alkaline cleaners. Wipe up spilled brake or battery fluid at once as they may damage the plastic surface.

## INSTALLATION

### CAUTION:

- To prevent burns, allow the engine, exhaust system, radiator, etc., to cool before installing the accessory.

### NOTE:

- Take care not to damage the painted surfaces of the motorcycle.
- Heat the bonding surfaces with a hair dryer if the ambient air temperature is below 70°F (21°C).
- The adhesive reaches full strength in 72 hours. Wait at least 24 hours before riding your motorcycle.

1. Refer to the Service Manual for the motorcycle, remove the lower cowl

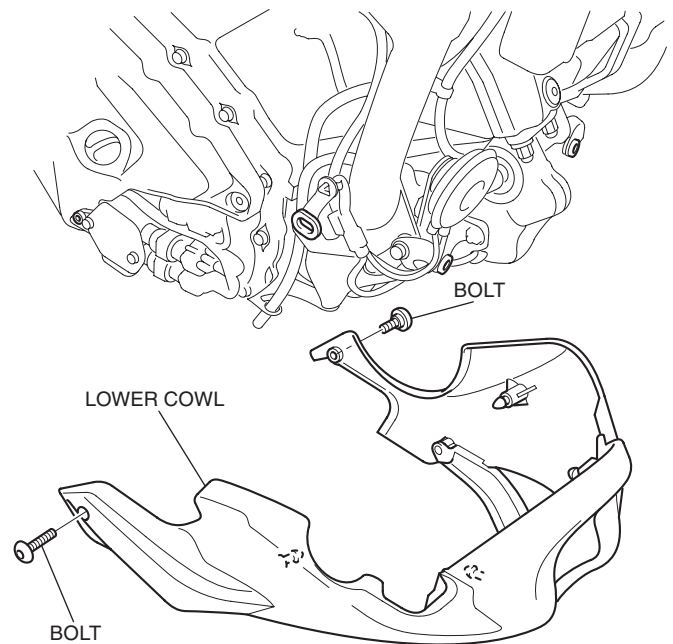

- Refer to the Service Manual for the motorcycle, disassemble the lower cowls as shown.

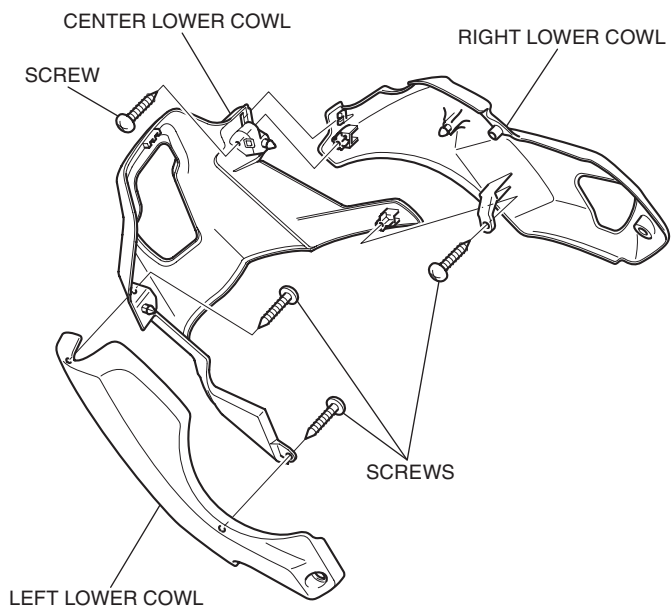

- Cut and attach the templates to the inside of the lower cowls and mark them using an awl as shown.

<RIGHT SIDE>

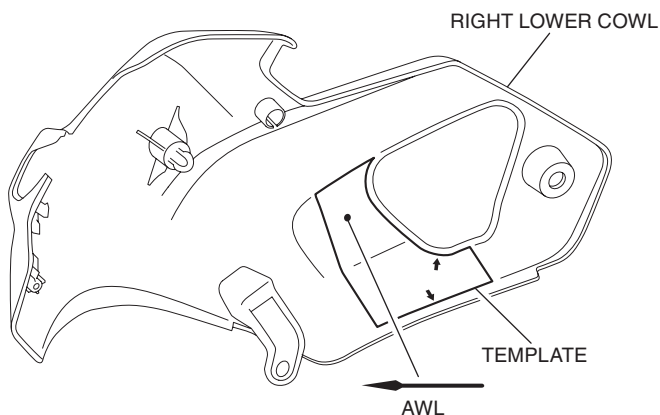

<LEFT SIDE>

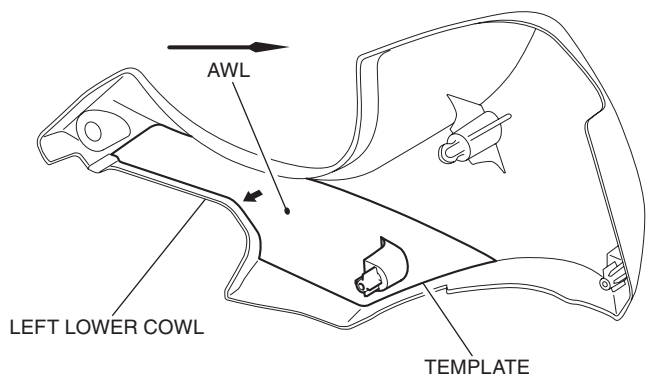

- Remove the templates. Drill at the marked point shown using an electric drill.

- Remove any burrs from the edge of the hole.

<RIGHT SIDE>

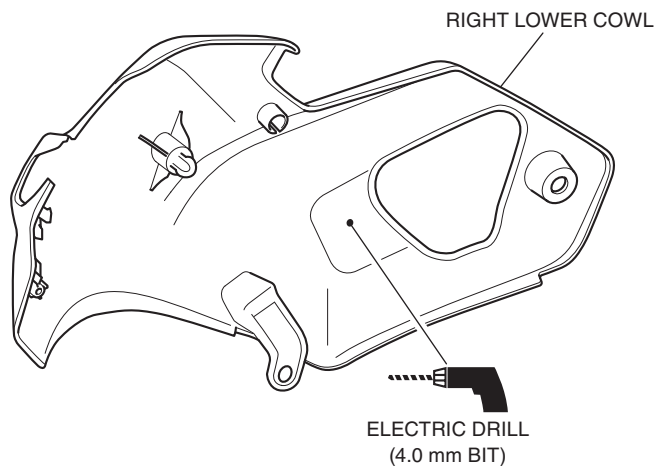

<LEFT SIDE>

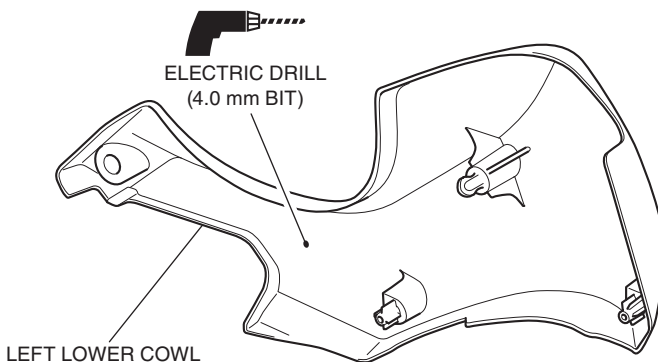

- Assemble the lower cowls in the reverse order of disassembly.
- Install the lower cowl in the reverse order of removal.
- Peel back an end of the adhesive backings on the back of the right deflector as shown.

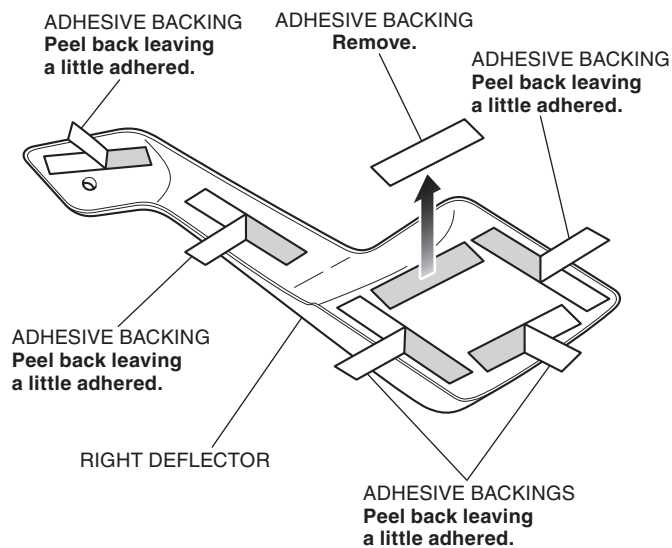

8. Loosely install the right deflector as shown.

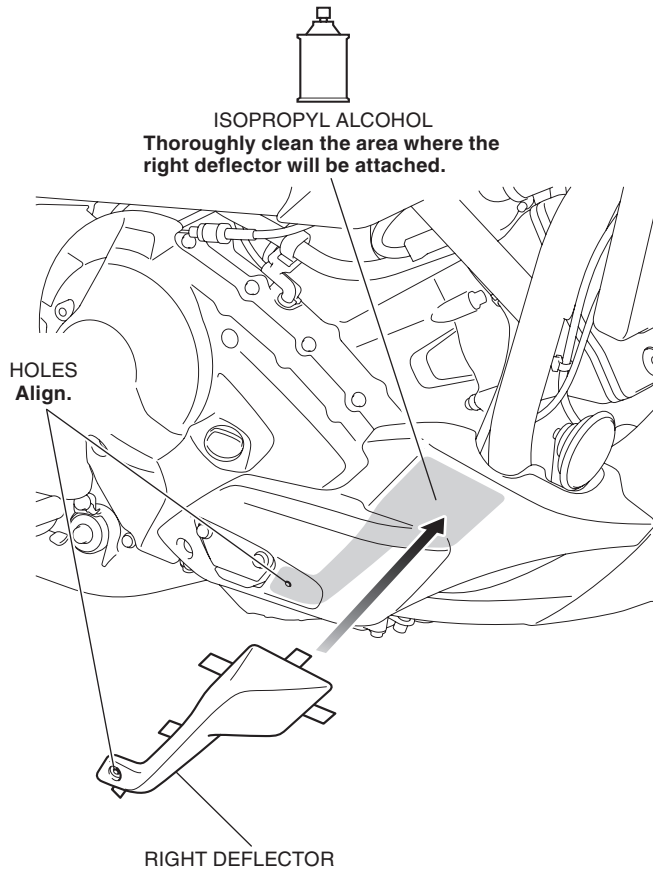

9. Install the right deflector securely as shown.

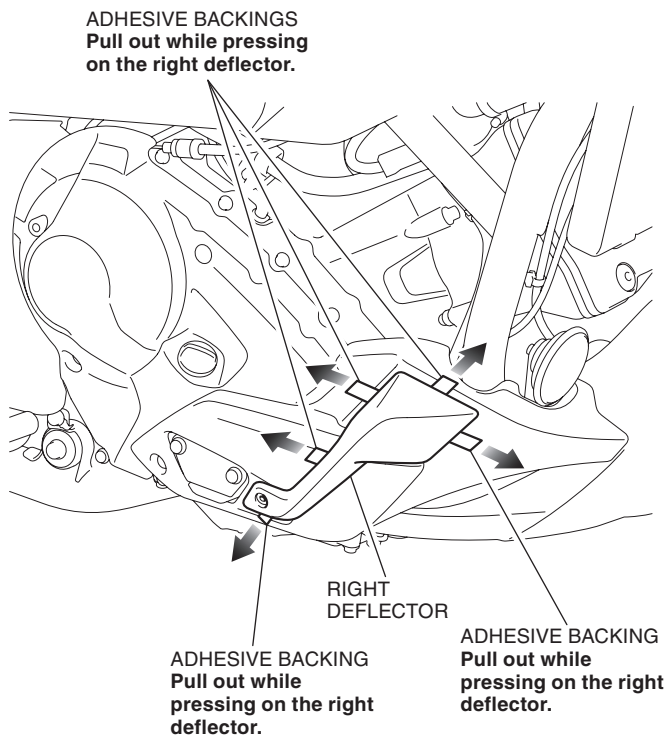

10. Apply adequate pressure to the attached right deflector.

11. Install the clip as shown.

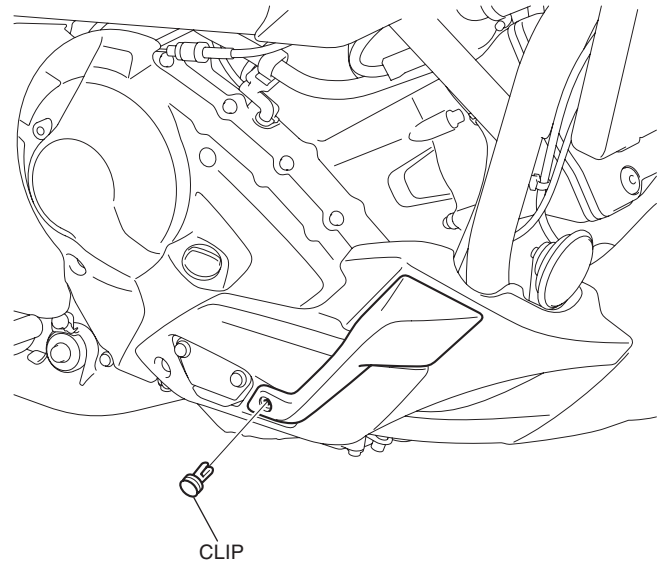

12. Peel back an end of the adhesive backings on the back of the left deflector as shown.

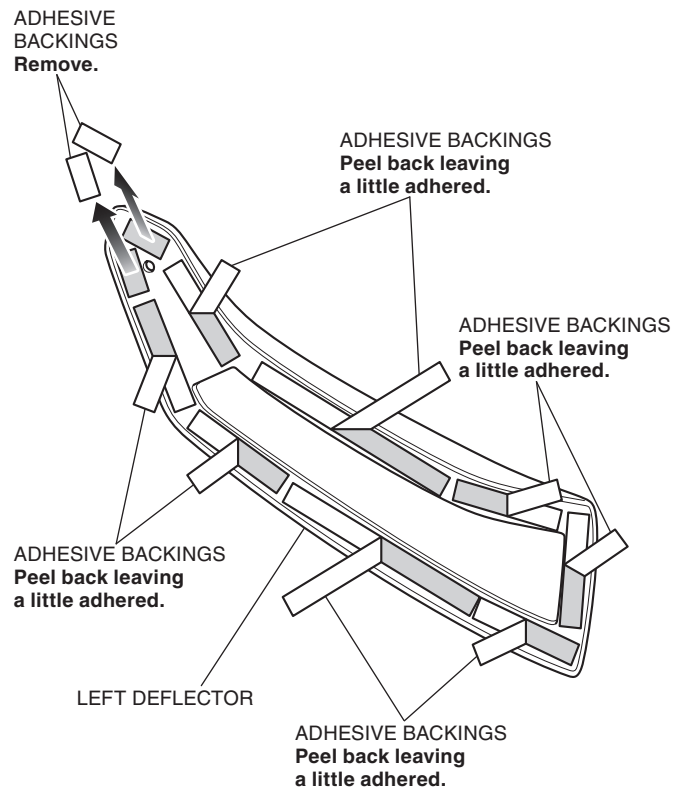

13. Loosely install the left deflector as shown.

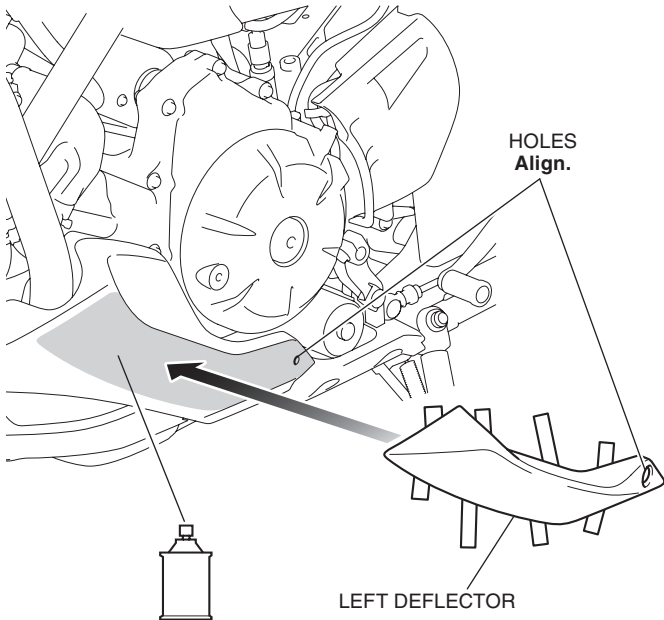

Thoroughly clean the area where the left deflector will be attached.

14. Install the left deflector securely as shown.

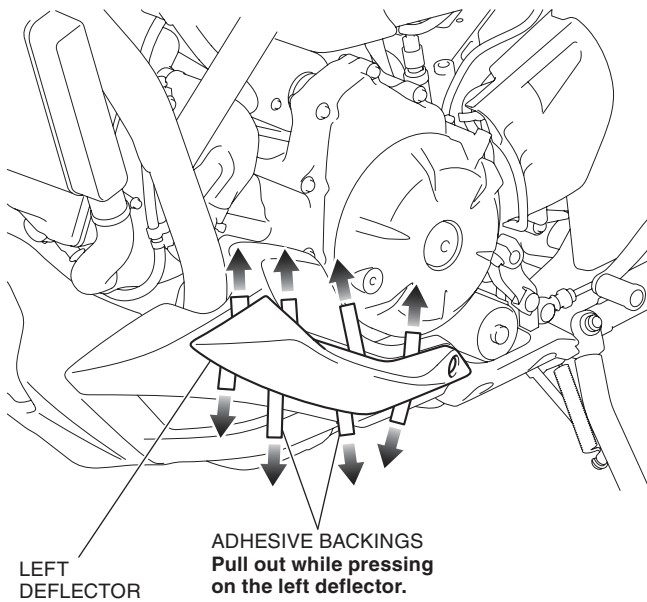

15. Apply adequate pressure to the attached left deflector.

16. Install the clip as shown.

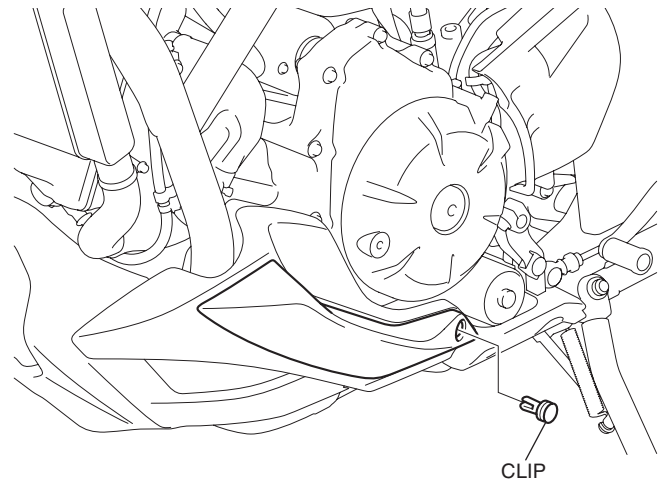

# <TEMPLATE>

Cut off along the dotted line.

## <RIGHT SIDE>

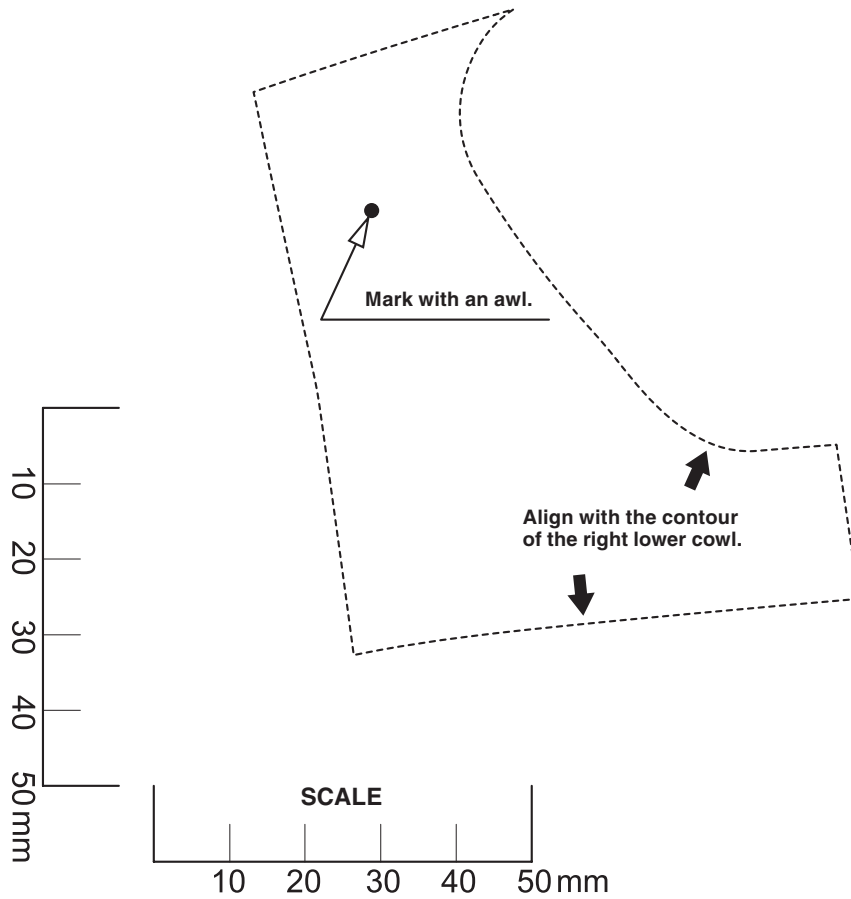

### NOTICE

If you print this template from your local computer, make sure the printer settings do not “scale” or “shrink” the page.



# <TEMPLATE>

<LEFT SIDE>

Cut off along the dotted line.

## NOTICE

If you print this template from your local computer, make sure the printer settings do not "scale" or "shrink" the page.

